

Panelboard and Switchboard Short Circuit Current Ratings

Questions often arise about how to install UL Listed panelboards and switchboards so that the overcurrent protective devices within the equipment have the ability to clear a fault without extensive damage to the equipment, as required by Sections 110.9 and 110.10 of the National Electrical Code (NEC).

Listed products installed and used in accordance with their listing are considered by the NEC to meet these requirements. Short circuit current ratings (SCCR) and available interrupting current (AIC) ratings marked on the equipment provide the information needed to provide a safe, code complying installation.

Circuit breakers and fuses are listed in accordance with ANSI/UL 489 and UL 248 series standards, and are covered under the DIVQ and JDDZ product categories, respectively. These overcurrent protective devices are marked with an interrupting rating and must be sufficiently rated to handle the available fault current at the intended voltage of the overcurrent protective device. Molded case circuit breakers are required to be marked with the AIC rating, when it exceeds 5000 amperes.

Panelboards and switchboards are Listed in accordance with ANSI/UL 67 and ANSI/UL 891, and are covered under the QEUY and WEVZ product categories, respectively. This equipment is subjected to short circuit tests¹ using test current equal to its marked maximum SCCR. After being subjected to short circuit conditions, the mechanical condition of the equipment must be substantially the same as its condition prior to the test, no live parts can become exposed, and

components within the equipment cannot be significantly damaged.

The available fault current for which the panelboards and switchboards must be rated is typically found on the electrical one-line diagram. The electrical engineer for the project should obtain the available fault current from the serving utility company and then calculate the available fault current for all panelboards and switchboards in the electrical system. Once the available fault currents are identified, the system can be designed to provide an acceptable level of short circuit protection using methods referred to as either fully rated systems or series rated systems.

Fully rated systems —

In the most simplistic terms, a fully rated system is one in which all of the electrical equipment (panelboards, switchboards, and overcurrent protective devices) is installed with SCCR or AIC ratings equal to or greater than the available fault current to which they might be subjected.

For example, if a panelboard has a 65K ampere SCCR, with 65K ampere AIC rated circuit breakers, the “full rating” (SCCR) is 65K ampere. If the panelboard has a 65K

Field markings for series rated systems

Replacing an overcurrent device in a series rated system with one that has not been investigated as part of the combination can result in significant safety concerns. In order to reduce the risk of an improper replacement circuit protective device being installed, NEC Section 110.22 (C) requires the equipment enclosure(s) to be legibly marked in the field by the installer to indicate the equipment has been applied with a series combination rating. The marking shall be readily visible and state the following:

CAUTION — SERIES COMBINATION SYSTEM RATED ____ AMPERES. IDENTIFIED REPLACEMENT COMPONENTS REQUIRED.

ampere SCCR, with 22K ampere AIC rated circuit breakers, the “full rating” is 22K ampere. Conversely, if the panelboard has a 65K ampere SCCR with a 100K ampere AIC rated circuit breaker, the “full rating” is still

continued »

¹ The UL Standards allow exceptions to this testing under certain conditions.



Panelboard and Switchboard Short Circuit Current Ratings (continued)

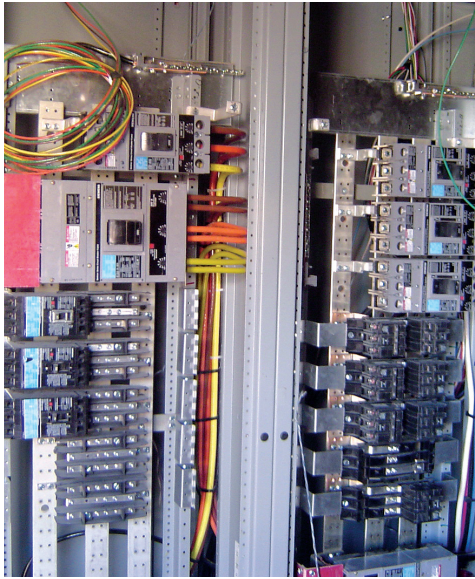

65k. In other words, the “full rating” of a panelboard or switchboard is based on the lowest rating of either the equipment or any of the overcurrent protective devices installed within the equipment.

Series rated systems — NEC Section 240.86 includes requirements that allow a circuit breaker to be used on a circuit having an available fault current higher than the marked interrupting rating, provided it is connected on the load side of an acceptable overcurrent protective device having a higher rating, and provided that the series combination complies with specific requirements. The combination of these devices has been found to work together under fault conditions to clear the fault and protect the equipment. This combination is referred to

as a series rated system.

marked with their electrical ratings, including their SCCR. A typical marking would read, “Short-Circuit-Current Rating 65,000 RMS symmetrical amperes”. If the unit contains meter mounting equipment other than those for use with current transformers, they are also marked “Watt-hour meter not included in short-circuit-current rating”.

Panelboards and switchboards that have been investigated for use as series rated systems include additional markings that identify the combinations of integral or remote line and load side overcurrent-protective devices that are required to achieve the marked SCCR.

The marking is provided either on the panelboard or switchboard. Alternately, the marking may be provided in a pamphlet, manual or instruction sheet located on or in a pocket directed within the panelboard.

UL series rated combinations are subjected to short circuit testing using test currents equal to the panelboard or switchboard’s maximum rated short circuit current².

The system is tested with (1) a line side overcurrent protective device of the maximum overcurrent rating, and (2) a load side circuit breaker with the lower AIC rating, as specified in the panelboard or switchboard’s markings. The series rated system is subjected to short circuit testing in accordance with the UL 489 requirements for series combinations.

Markings — Listed panelboards and switchboards are required to be

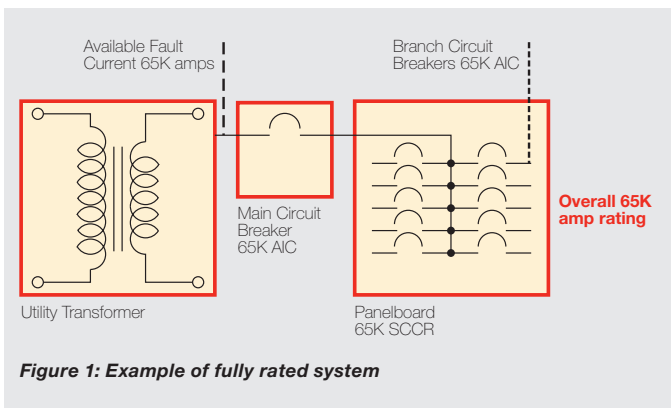

Figure 1: Example of fully rated system

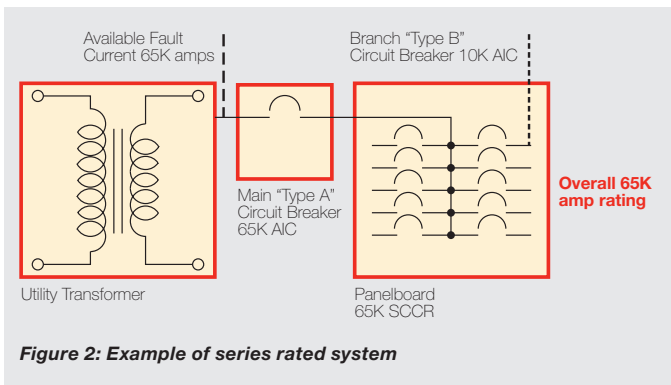

Figure 2: Example of series rated system

Branch Circuit Breaker				Main Circuit Breaker				Interrupting Rating		
Type	Amps	No. Poles	AIC Rating	Type	Amps	No. Poles	AIC Rating	Symmetrical Amps	V	Ph
B	15–50	1	10,000	A	100	2	65,000	65,000	120/240	1

Figure 3

² Testing using worst-case combinations may be representative of other combinations.